

Rack Type Energy Storage LiFePO₄ Battery

User manual



Important safety instructions

Important safety instructions

Please keep this manual for future reference.

This manual contains all the safety, installation and operation instructions of the rack type energy storage LiFePO₄ battery.

Please read all instructions and precautions in the manual carefully before installation and use.

1. To avoid personal injury, users should disassemble it by professional installer.
If need repairs, please contact our company's professional maintenance personnel.
2. Do not install the energy storage LiFePO₄ battery in a place where children can touch.
3. Do not install the energy storage LiFePO₄ battery in harsh environments such as damp greasy, flammable, explosive, or dust accumulation.
4. When the energy storage LiFePO₄ battery is working, please do not open the box.
5. It is recommended to install a suitable fuse or circuit breaker externally.
6. After installation, check whether all line connections are tight to avoid the risk of heat accumulation due to virtual connection.
7. Rack energy storage battery shall be charged with solar power or AC power supply, parallel connection with other AC power supply or different voltage and brand batteries is prohibited.

Contents

1. Basic information	3~4
2. Installation process	4~5
3. Parallel structure diagram	6
4. LED instructions	7~8
5. BMS communication settings	8~9
6. Technical parameter list	10
7. Maintenance and conservation	11
8. Warranty record card	12

1. Basic information

1.1 Product overview

Rack type energy storage battery is mainly used in the field of household power storage. At the same time, it is also suitable for the internal energy storage of RV, household energy storage and temporary buildings. It adopts high-performance and long-life lithium iron phosphate battery as the basic energy storage unit, combined with advanced lithium-ion battery management system industrial design of household products and other technologies. Ensure that products have high reliability and high industrialization standards. Rack type energy storage battery covers the energy demand of a single machine from the 2.5kwh to 5.0kwh.

Rack type products have wall mounting function and can support external parallel use function, which greatly improves the convenience of use.

Through scientific and reasonable active heat dissipation. Rack type energy storage battery improves the consistency of internal temperature field, prolongs service life, and enables the product to continuously output high current.

1.2 Features

- ◆ The battery adopts high-performance lithium iron phosphate battery with high safety performance and long service life.
- ◆ External weak current switch reduces product power consumption and improves the safety of transportation and storage.
- ◆ With RS485/CAN communication function, it can easily communicate with the equipment with communication.
- ◆ External wireless module can be connected for remote data monitoring and corresponding control.
- ◆ It has multiple protection functions to protect the safety of power supply in an all-round way.
- ◆ The output is stable and can be connected to different loads within the voltage range.
- ◆ Support up to 15 independent modules for parallel use.

1.3 Function description

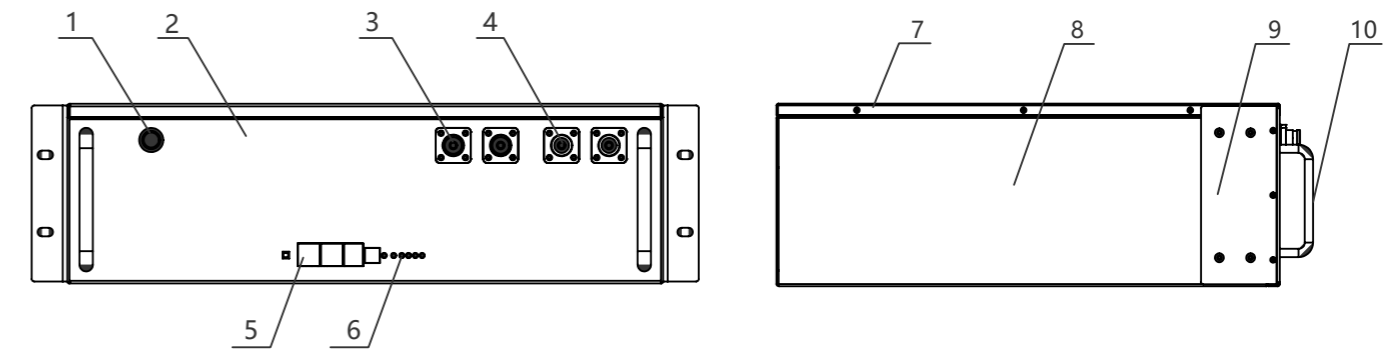

1	On/Off	6	Battery indicator
2	Interface	7	Welding parts of upper cover
3	Red terminal	8	Box
4	Black terminal	9	Box fixings
5	RS485/CAN communication	10	Box handle

2. Installation instructions

2.1 Installation notes

Before installation, please read this manual carefully and familiarize the installation steps.

- (1) Be sure to leave a certain space around for heat dissipation during installation.
- (2) Avoid sunlight direct and rainwater infiltration during outdoor installation to cause battery damage.
- (3) Do not place metal products near the place of the energy storage LiFePO₄ battery installation to prevent short circuits.
- (4) Virtual connection points and corroded wires may generate high heat, and the molten insulation layer will burn surrounding materials and even cause a fire. Therefore, it must be ensured that the connector has been tightened and the wires should be secured with cable ties to avoid loosening of the connector due to shaking during mobile applications.
- (5) After the battery switch is turned off, there is still high voltage inside the energy storage case. Please do not open or touch the internal components, and external short circuit is strictly prohibited.

- (6) Please do not install it in a harsh environment where a large amount of damp, greasy, flammable and explosive dust gathers.
- (7) It is forbidden to reverse the charging and discharging terminals of the battery, otherwise it is very easy to damage the battery or cause unpredictable risks.
- (10) If an injury occurs during installation or use, please seek medical attention in time.

2.2 Installation and connection

Installation and connection must comply with national and local electrical code requirements. According to the current situation, firstly, choose the corresponding wire or wire with a larger wire diameter to avoid unnecessary troubles during use. Secondly, determine the installation location. Thirdly, when installing, please make sure to leave at least 200 mm of space at the air outlets on both sides of the energy storage battery to ensure natural convection heat dissipation.

2.3 Recommended external wiring diameter and switch selection.

Model	Recommended external wiring diameter	Battery continuous current circuit breaker	Circuit breaker Model
M15S-U050BL	25mm ² /4AWG	50A	2P-125A
M15S-U100BL	25mm ² /4AWG	100A	2P-125A
M16S-U100BL	25mm ² /4AWG	100A	2P-125A

Note: The wiring diameter is for reference only. If the distance between the load and the battery is relatively long, use a larger wire to reduce the voltage and improve the system performance. The above wiring diameter and circuit breaker are only recommendations, please follow the actual choice of the appropriate wire diameter and circuit breaker according to the situation.

2.4 Recommended setting data of inverter:

Battery model	LiFePO ₄ /Lithium battery		
	M15S050BL-U	M15S100BL-U	M16S100BL-U
Discharge cut-off voltage	42	42	46
Over discharge recovery	44	44	48
Normal charging voltage	58.4	58.4	58
Surge charging voltage	58	58	60
Overvoltage protection	54.8	54.8	58.4
Overvoltage recovery	52	52	56

3. Parallel structure diagram

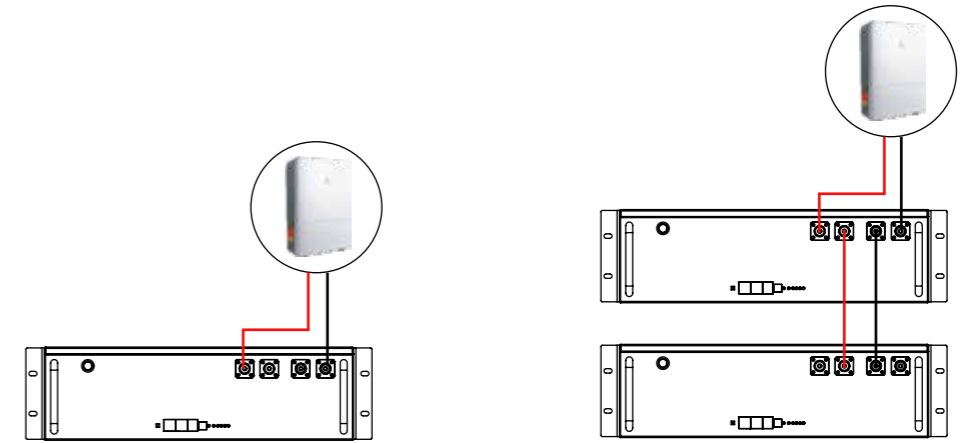

① One unit product

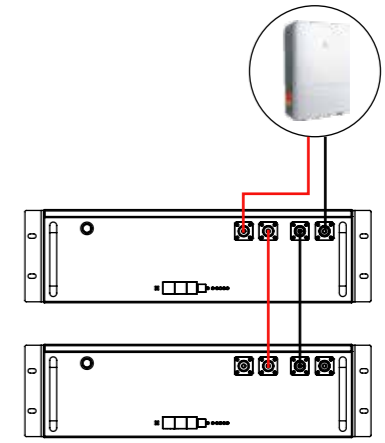

② Two units products

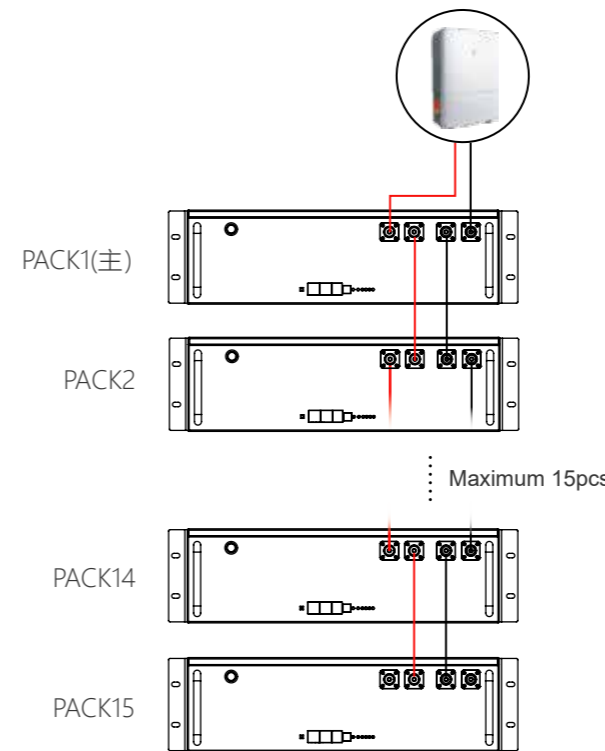

③ Batteries are connected in communication

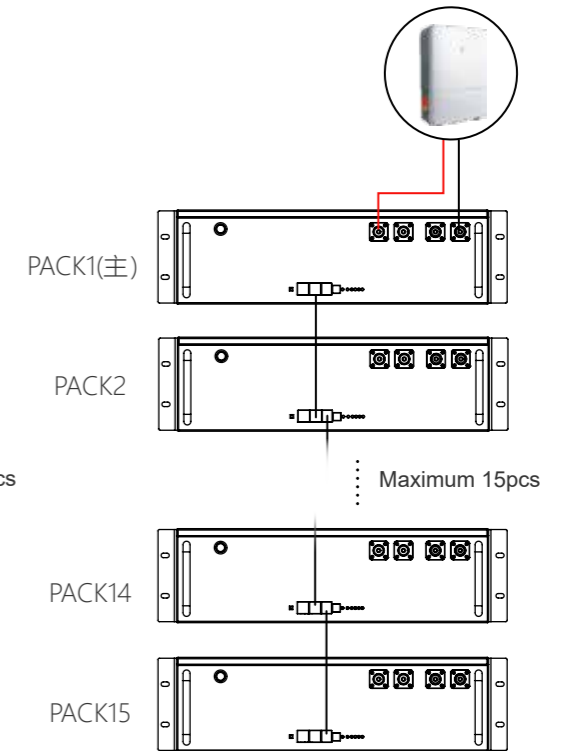

- Note: 1. When the battery pack is used in parallel, it is necessary to distinguish different packs by hardware address, and the hardware address of each pack in the whole battery pack is unique.
- 2. It must set up a pack for the host pack. The inverter communicate with host pack via PRS485/CAN. The hardware address can be set successively through the dial switch on the board.

4. LED instructions

Table1 LED working status indication

state	normal/warning/protect	RUN	ALM	Battery indicator LED				illustrate
		●	●	●	●	●	●	
shutdown	hibernate	extinguish	extinguish	extinguish	extinguish	extinguish	extinguish	annihilate
Standby	normal	flash 1	extinguish	According to the battery indicator				standby mode
	alert	flash 1	flash 3	According to the battery indicator				Module low voltage
Charge	normal	Always bright	extinguish	According to the battery indicator (battery indication maximum LED flashes 2)				Maximum battery LED flashes Move (flashing 2), overcharge warning ALM does not flash during alarm
	alert	Always bright	flash 3	According to the battery indicator				
	Overcharge protection	Always bright	extinguish	Always bright	Always bright	Always bright	Always bright	If there is no utility power, indicate Light goes to standby
	temperature, overcurrent, Failsafe	extinguish	Always bright	extinguish	extinguish	extinguish	extinguish	stop charging
discharge	normal	flash 3	extinguish	According to the battery indicator				stop charging
	alert	flash 3	flash 3	According to the battery indicator				stop charging
	Undervoltage protection	extinguish	extinguish	extinguish	extinguish	extinguish	extinguish	stop charging
	temperature, overcurrent, short circuit, Reverse connection, failsafe	extinguish	Always bright	extinguish	extinguish	extinguish	extinguish	stop charging
invalid		extinguish	Always bright	extinguish	extinguish	extinguish	extinguish	Stop charging and discharging

Table2 Description of capacity indication

state		Charge				discharge			
capacity indicator		L4 ●	L3 ●	L2 ●	L1 ●	L4 ●	L3 ●	L2 ●	L1 ●
Battery (%)	0~25%	extinguish	extinguish	extinguish	extinguish	extinguish	extinguish	extinguish	constant
	25~50%	extinguish	flash 2	flash 2	constant	extinguish	extinguish	constant	constant
	50~75%	flash 2	flash 2	constant	constant	extinguish	constant	constant	constant
	75~100%	flash 2	constant	constant	constant	constant	constant	constant	constant
Running lights ●		constant				Blink (blink 3)			

Table 3 LED flashing description

flashing method	Bright	extinguish
flash 1	0.25S	3.75S
flash 2	0.5S	0.5S
flash 3	0.5S	1.5S

Remarks: The LED indicator alarm can be enabled or disabled through the host computer, and the factory default is enabled.

◆ Key Description

1. When the BMS is in sleep state, press the button (3~6S) and release it, the protection board will be activated, and the LED indicators will light up sequentially from "RUN" for 0.5 seconds.
2. When the BMS is active, press the button (3~6S) and release it, the protection board will be put to sleep, and the LED indicators will light up sequentially for 0.5 seconds from the lowest battery indicator.
3. When the BMS is active, press the button (6~10S) and release it, the protection board will be reset, and all the LED lights will light up at the same time for 1.5 seconds.
4. After the BMS is reset, the parameters and functions set by the host computer are still retained. If it is necessary to restore the initial parameters, it can be achieved through the "restore default value" of the host computer, but the relevant operation records and stored data remain unchanged (such as power, cycle times, etc.).

5.BMS communication settings

5.1 BMS communication and setting

When the load (such as inverter) needs to communicate with the battery, in order to establish normal communication with the load, BMS needs to set the following settings for each brand. The RS485 communication protocols of inverters are different, but there are several RS485 communication protocols inside the inverter to match the battery. When using, you can directly select the communication protocol code in the inverter for matching. If you have other problems, please consult the supplier.

Battery BMS interface pin foot definition as shown in the following figure

ADS

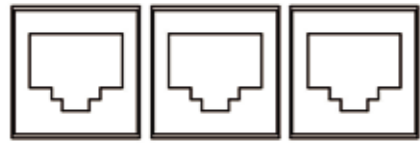

RS485 RS485 PRS485/CAN



“ADS” is used for parallel use of battery packs. PACK can be distinguished by hardware address. The definition of ADS master-slave address refers to communication address selection specification. “PRS485/CAN” battery pack can communicate with the upper computer or inverter and the reverse control integrated machine through the interface. “RS485” is used in parallel for battery pack, and the main pack communicates with pack from the interface.

The battery communication interface adopts 8P8C RJ45 socket.

RS485		PRS485/CAN	
PIN	Definition	PIN	Definition
1、8	RS485-B	1、8	RS485-B
2、7	RS485-A	2、7	RS485-A
		4	CAN-H
		5	CAN-L

5.2 Communication address selection specification

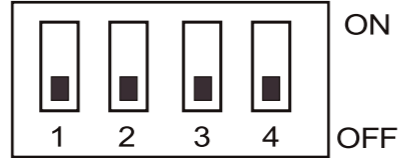

address	Code switch position				Illustrate
	1#	2#	3#	4#	
0	OFF	OFF	OFF	OFF	Stand-alone use, no cascade
1	ON	OFF	OFF	OFF	Set to Pack 1 (Host)
2	OFF	ON	OFF	OFF	Set to Pack 2
3	ON	ON	OFF	OFF	Set to Pack 3
4	OFF	OFF	ON	OFF	Set to Pack 4
5	ON	OFF	ON	OFF	Set to Pack 5
6	OFF	ON	ON	OFF	Set to Pack 6
7	ON	ON	ON	OFF	Set to Pack 7
8	OFF	OFF	OFF	ON	Set to Pack 8
9	ON	OFF	OFF	ON	Set to Pack 9
10	OFF	ON	OFF	ON	Set to Pack 10
11	ON	ON	OFF	ON	Set to Pack 11
12	OFF	OFF	ON	ON	Set to Pack 12
13	ON	OFF	ON	ON	Set to Pack 13
14	OFF	ON	ON	ON	Set to Pack 14
15	ON	ON	ON	ON	Set to Pack 15

6. Technical parameter list

Product number	M15S050BL-U	M15S100BL-U	M16S100BL-U
Array Mode	15S	15S	16S
Nominal Energy (KWh)	2.4	4.8	5.0
Minimum Energy (KWh)	≥4.92	≥10.0	≥10.0
Nominal Voltage (V)	48	48	51.2
Charge Voltage (V)	54.7	54.7	58.4
Discharge Cut-off Voltage (V)	42	42	45
Standard Charging Current	10	20	20
Max.Continuous Charging Current	50	100	100
Max.Continuous discharging Current	50	100	100
Communication Mode	≥6000次@80%DOD, 25°C		
Cycle Life	RS485/232	RS485/CAN	RS485/CAN
Operating Temp	Charging: 0~60°C; Discharging: -10°C~65°C		
Size (L×W×H) mm	453×493×133	515×493×180	515×493×180
Weight (Kg)	27.5	41.5	45
Package dimensions (L×W×H) mm	587×537×344	587×537×344	587×537×344
Gross weight (Kg)	45.4	51.5	55.5

Note: The dimensions in the datasheet are the product appearance dimensions. If any change for the products, will adjusted by the manufacture.

7. Maintenance and conservation

Item	Problem description	Description/possible causes	Solution
1	Unable to boot properly, BMS will immediately enter the protection state after press the switch	The external load does not match, and the instantaneous current of load startup is too large	1. Press the on key to restart 2. Reduce load power
2	Automatically disconnect the output during use	1. The battery voltage is too low 2. Output or load short circuit	1. Charge the battery 2. Disconnect the load and restart the battery
3	The Communication fault occurs when the load is inverter	1. Communication line connection error (connecting pin improper connection or oxidation) 2. The internal protocol code of inverter is not properly chosen 3. Communication insert loose or improper connection	1. Check the connection between BMS and inverter 2. Choose the corresponding communication protocol in the inverter's internal program 3. Reconnect the communication cables. If the problem still exists, please contact the manufacturer
4			
5			
6			

In order to maintain the best and long-term performance, the following items are recommended to be inspected twice a year.

1. Confirm that the surrounding air flow will not be blocked, and remove any dirt and debris on the cooling hole.
2. Check all exposed wires, shabby and damage, please replace or repair them if necessary.
3. If it is not used for a long time, it is recommended to charge it every three months.

 Danger of electric shock! Make sure that the power supply has been disconnected during the above operations, and then carry out corresponding inspection and operation.

8. Warranty record card

Dear Customers:

Hello! Thank you very much for purchasing our products. In order to serve you better, please read and fill in and keep this warranty card after purchasing the product. In order to avoid your worries, our company hereby makes a warranty service commitment and provides standardized after-sales service accordingly.

Exemption of warranty liability scope:

1. Damage caused by man-made or other natural disasters.
2. Failure caused by incorrect operation and installation or use in an environment other than the product's prescribed use.
3. Damage caused by unauthorized disassembly and modification.

Contact: _____ Number: _____

Tel: _____ Email: _____

Purchase date: _____

Address: _____

Maintenance records			
Repair Date	Repair content	Repair Person	